

# Addressable Intelligent Flame Proof Gas Leak Detector

Model No - AA103FLPG



## Overview:

This Addressable Flame Proof Gas Leak Detector is designed to detect and alert the leak of flammable gases. The alarming detector with a unique ID communicates to the control panel to alert the exact location of emergency. This device mainly designed for gas bank at hotel, residential complex, Hotel kitchen, industries etc.,

## Specification

### Electrical Specifications

<b>Power supply</b>	17-27V DC
<b>Power consumption</b>	1W
<b>Sensitivity</b>	Butane LEL:1.8 vd% / HEL(UEL):8.4 vd% Propane LEL:2.1 vd% / HEL(UEL):9.5 vd% Methane LEL:5.0 vd% / HEL(UEL):15 vd%
<b>Detection distance</b>	LPG - 30cm above the ground on the wall Coal gas, Natural gas - 30cm below ceiling

### General Specifications

<b>Operating temperature</b>	0°C to 49°C
<b>Storage temperature</b>	5°C to 40°C
<b>Humidity</b>	0-95% RH (Non-condensing)
<b>Wiring</b>	2 Core
<b>Compatibility</b>	AU101X Protocol
<b>Type of protection</b>	Flameproof-Fp
<b>Area classification</b>	Safe area
<b>Apparatus standard</b>	IS-13947/93
<b>Colour</b>	Red

### Mechanical Specifications

<b>Dimensions(HxWxD)</b>	155x135x75mm
<b>Weight</b>	3kg(Approx.)
<b>Material</b>	Aluminium Lm6
<b>IP Protection</b>	IP 65
<b>Finish</b>	Anti corrosive epoxy Powder coated
<b>Cable Entry</b>	2 x 3/4" ET
<b>Gasket</b>	Neoprene
<b>Hardware</b>	Stainless Steel(SS-304)

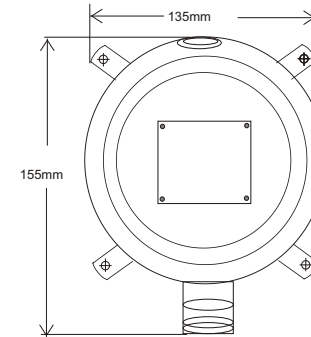

Complied with:

